

HAZEMAG



HAZEMAG Recycling





Partnership

Rubble-Recycling

The very foundation of The HAZEMAG Company started with the processing and recycling of rubble. Our founder, Dr. Erhard Andreas developed and introduced the Andreas Impactor, the very first mill of its kind that was utilized, post war, for the processing of the massive amount of waste and debris that dominated throughout many cities in Germany. Rubble recycling as we know it today, began with this highly successful introduction of the HAZEMAG Andreas impactor. Now, some 70 years later, this recycled and acceptable resource is being used and enjoyed in many aspects of our daily lives; benefiting all of us while giving life to a previously used and valuable resource once again. With its process know-how, high quality – reliable machines and services, HAZEMAG plays an important and highly contributing role in the crushing and recycling of materials such as rubble, concrete and asphalt; resulting in a proven component that can be utilized in a wide range of construction sectors.

Partnership

Behind the operation of every HAZEMAG product is found a wealth of experience, backed by a level of partnership and product support that remains second to none. Our application knowledge, equipment flexibility and market competitiveness puts us in a unique position to react to your precise project needs. We call it “Partnership Unlimited – the HAZEMAG Way”.

Since 1946: Our journey started in 1946 with our introduction of the impact crusher. Today, our customers benefit from an extensive range of HAZEMAG services; realized in our industry knowledge, qualified experts, proven products, financial resources and innovative technologies and solutions. Now, some 70 years later, we have not forgotten our strongest growth asset; our customers that have looked to us as a proven, reliable partner. Your project starts with planning. As your partner we will

introduce the correct equipment and systems. Our services continue with state of the art manufacturing facilities, equipment supply and delivery, on-site installation, commissioning, training and future spare parts support. Simply put, our partnership will be there, supporting your needs through-out the life cycle of your HAZEMAG equipment; be it a single crusher or a complete system.

Going Forward: The continued operation and reliable success of any HAZEMAG component or system is directly related to trained, knowledgeable plant personnel. HAZEMAG’s training concept and support services offer a common sense approach to meeting your needs. Our team of experienced, knowledgeable service technicians are there for you, ensuring that you know and understand your HAZEMAG equipment from every aspect; operation, service needs, safety and optimization.

Recycled Materials: The Possibilities Are Extensive

The recycling of building materials results in a level of consumer and environmental benefits that go far beyond “just reducing waste”. Recycled materials continue to prove their value; contributing to the cost savings benefits and success of construction projects around the world. For example, recycled concrete serves as an excellent base material for residential road, highways and commercial construction projects. It has been proven and accepted as a valued aggregate in those regions where natural deposits of minerals, such as limestone, do not exist. For the recycling group, the ability to capitalize on the extracted tramp iron or steel adds to the profitability of the recycling operation. The recycling of asphalt offers a very notable benefit found in its ability to be re-utilized back into the process of producing new asphalt materials; resulting in a notable petroleum additive cost savings. In summary, the benefits and application of recycled materials is truly extensive; contributing to the improvement of our environment and life.



Concepts, Trials & Proven Methods

Perhaps more than many other industries, the success of the recycling group is highly determined by the control and management of the raw, available materials. To achieve this, the processing system must offer a very high level of flexibility, extreme ruggedness, high technology and the ability to adapt to an extensive variation range in the raw materials. The decision between a fixed/stationary plant versus a mobile plant are solely determine by the availability of raw materials, annual projected production rates and the local demand for the recycled products. Under the correct management controls, the success and profitability of a recycling facility can easily be realized.

Quality control, raw material management and the needed processing methods are realized in a variety of ways, such as;

- selective demolition of buildings
- inspection/monitoring of the incoming material
- raw material stockpiling according to its makeup/ mixture
- material preparation: pre-sizing, sorting and removal of larger tramp irons
- raw material identification, classifying and selective sorting
- metal identification, preparation and possible removal
- sorting out of non-mineral fractions
- separation of light materials

The Task At Hand: What Is Known / What Can Happen

In any recycling facility, the design of the processing plant will be defined by the makeup and characteristics of feed material. The flexibility and components that make up the plant must be capable of processing a raw feed material that can range from clean building rubble, mixed building rubble and large concrete products; all of which can potentially contain large amounts of tramp irons.

The requirements on the finished product; defined as the grain size and needed distribution of each, product shape requirements, material composition and perhaps most important its quality in regard to purity, clean materials, will define and reflect the plants level of technology and automation.

Target of Processing: A Saleable Product

The successful processing of a wide range of demolition and construction debris into an acceptable, saleable product is the target of processing. This is particularly relevant in the business of rubble processing, where crushing and screening plants are commonly employed.

Plant Selection Criteria

- Define the feed material (building rubble)
- Define the size of the feed materials
- Define the composition of the finished products
- Define the needed purity of the finished products
- Define the required plant throughput rate
- Define/project the amount of waste that will be generated
- Define the required land area
- Define permitting requirements associated local codes



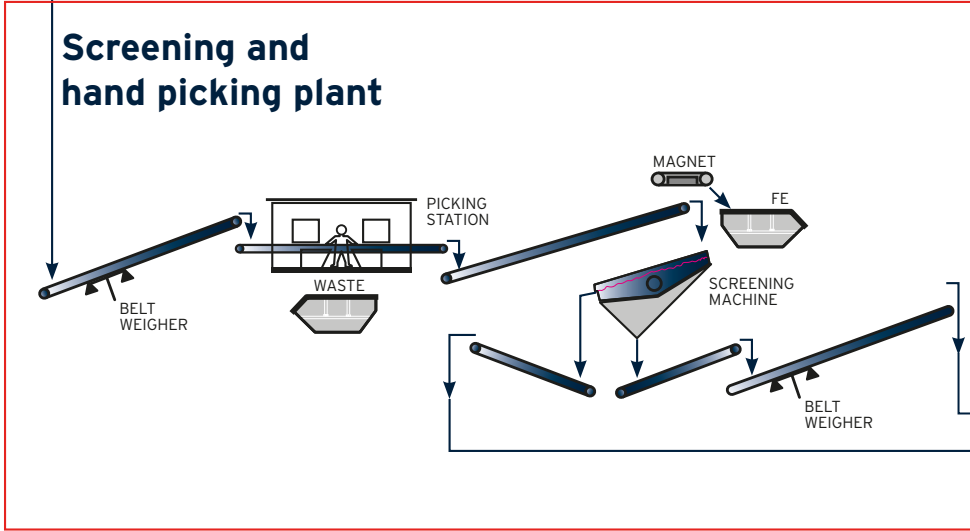
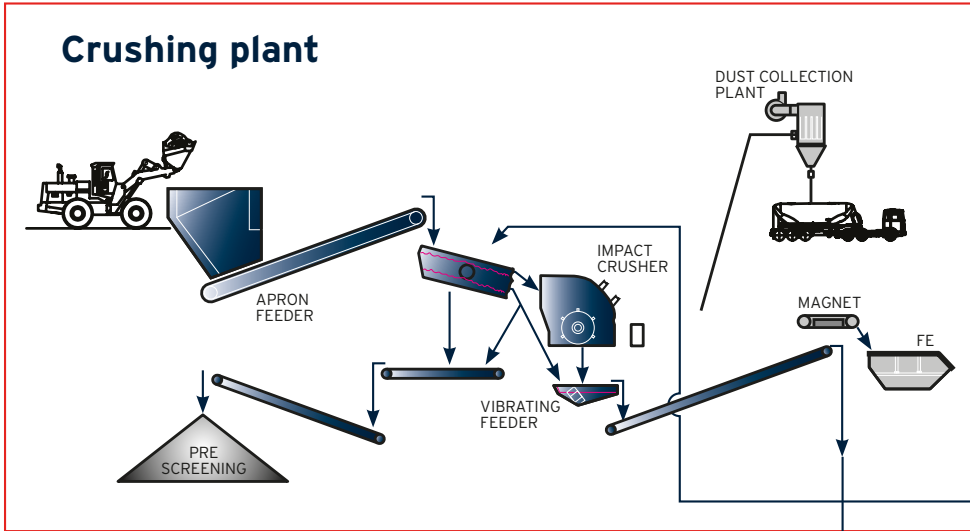



Screening and wind sifting plant

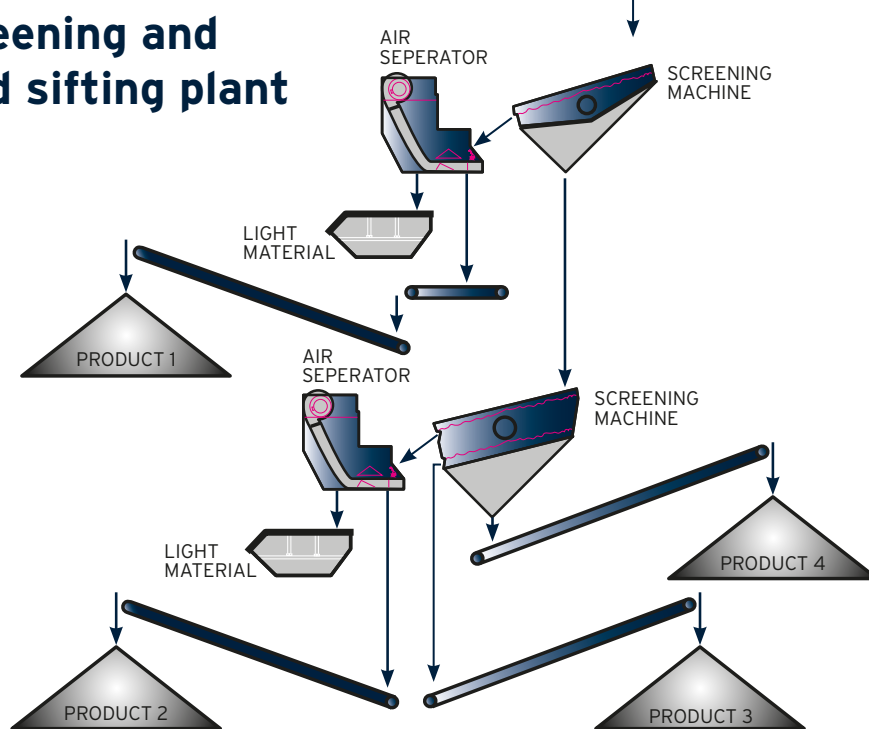

Example of a rubble recycling plant





Pointing The Way

Main System Components

For the processing of building rubble, the availability of proven machines and technology is certainly known. Although the overall design and selection of the ancillary machines can vary, the heart and key component of any recycling plant is found in its crushing unit; which without any doubt will help determine the success and profitability for any operation. Beyond the crushing unit, the typical ancillary units are;

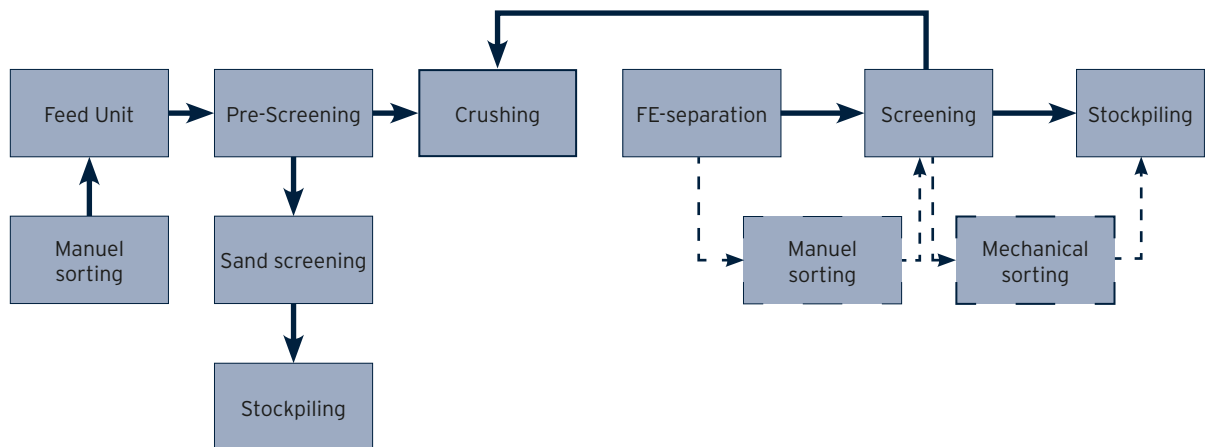

Ancillary units

- Crusher feed unit
- Under crusher discharge pan
- Material transfer conveyors
- Screening system
- Magnet for the removal of tramp irons
- Chutes and skids
- Dust suppression: spray or filter system
- Air systems
- Finished product stacking conveyors





**Challenges to Solutions:
HAZEMAG's "Pointing The Way" Concept**

Building rubble in itself presents a difficult task. Add the presence of basic tramp iron to the mix and it becomes very clear that the crusher must be designed and constructed in a manner that can take a high level of punishment. Add rebar; metal that can vary in length from short to excessively long, now the design of the plant must take into consideration the absolute need to maintain a uniform, unrestricted flow for

the material otherwise production stoppages and potential equipment damages are certain to occur. The key or target is to ensure that the design of the plant is robust and very well engineered in regard to accepting the raw material variation; ensuring a consistent, uninterrupted product flow and trouble free operation. In this regard, years of experience, trial and error and a solid learning curve have produced concepts; system designs that have been proven time and time again.

1) Horizontal Crushing: The HAZEMAG impact roll crusher, model HHI, provides an uninterrupted material flow from the raw feed to the crushed product, including the removal of tramp irons facilitated by the use of an inline belt magnet.

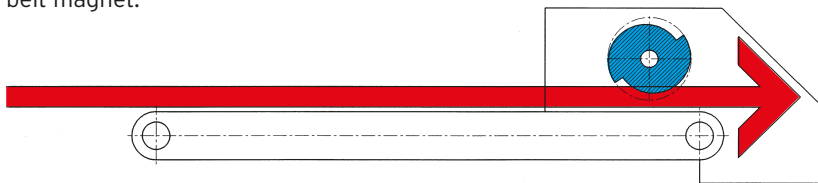

2) Pointing The Way: The HAZEMAG primary impact crusher, model HPI, provides an excellent solution for processing rubble. "Pointing The Way" ensures that the material flow through the crusher is not interrupted by its discharge system; thus the discharge vibrating pan is positioned in a manner that continues this uniform flow process. This common sense approach continues throughout the complete processing system; resulting in its trouble free operation, reduced downtime and a consistent product flow; crushed product and the removal of tramp irons.

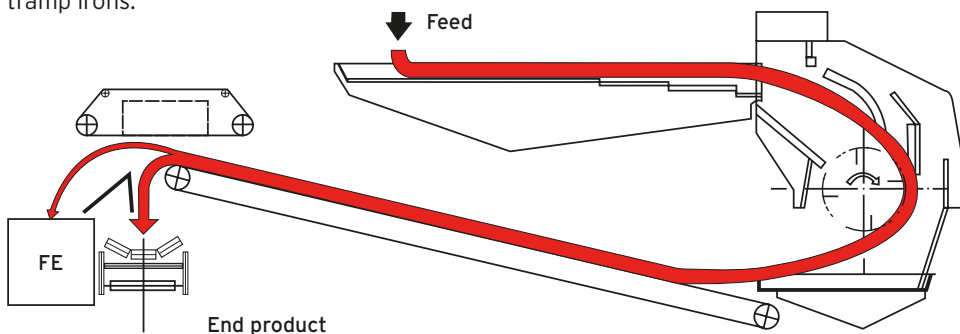



Fully Automated primary crusher

Recycling System: Its heart is found in the "Fully Automated" primary crusher; complete control, hydraulic apron adjustment and state of the art design.

The proven success of the HAZEMAG primary impact crusher, model HPI, is realized in high automation, proven reliability and its ability to selectively crush; a process where the concrete is crushed to a desirable product while its internal tramp iron is freed and removed in a very efficient manner. Due to its rugged design, proven reliability and highly automated, hydraulically apron adjustment control system, the HPI impactor has earned its title; the heart of the recycling system.

HAZEMAG HPI Crusher: Design, Technology and Proven Advantages

- Material reduction facilitated by an extra heavy duty primary rotor
- Ability to process higher strength materials; up to 300 MPa
- High crushing degree: up to 1:20
- Excellent, uniform product gradation; 0 - 56 mm is typical
- High quality finished product: cubical, increased soundness
- True selective crushing: metal is clean and free of concrete
- Resistance against wood and metal
- Extreme flexibility: simple adaptation to different feed materials
- Excellent product size control: influenced as you wish
- Automated, hydraulic apron adjustment and automatic reset system
- Hydraulic apron "back pressure": continuous positioning with the rotor

- Large inlet opening / moveable base: reducing the potential for blockages
- Interchangeable spare parts: standardized impact aprons & housing liners
- User friendly: fully automated, safe operation and consistent product control
- Reduced noise development

Hydraulic system

The impact aprons are retained in position by hydraulic cylinder, allowing adjustment and securing at the touch of a button. The instant a pre-set limiting value is overstepped in the crushing chamber, the impact apron retracts in a controlled manner. As soon as the load value returns to normal, the impact apron resumes its pre-set position, and operation continues without interruption.

QB-Rotor

The rotor discs are welded together with rugged holding beams to provide the backbone for the blow bars. The blow bars themselves are secured to the holding beams by means of wedges, which are easily removed for blow bar changing.



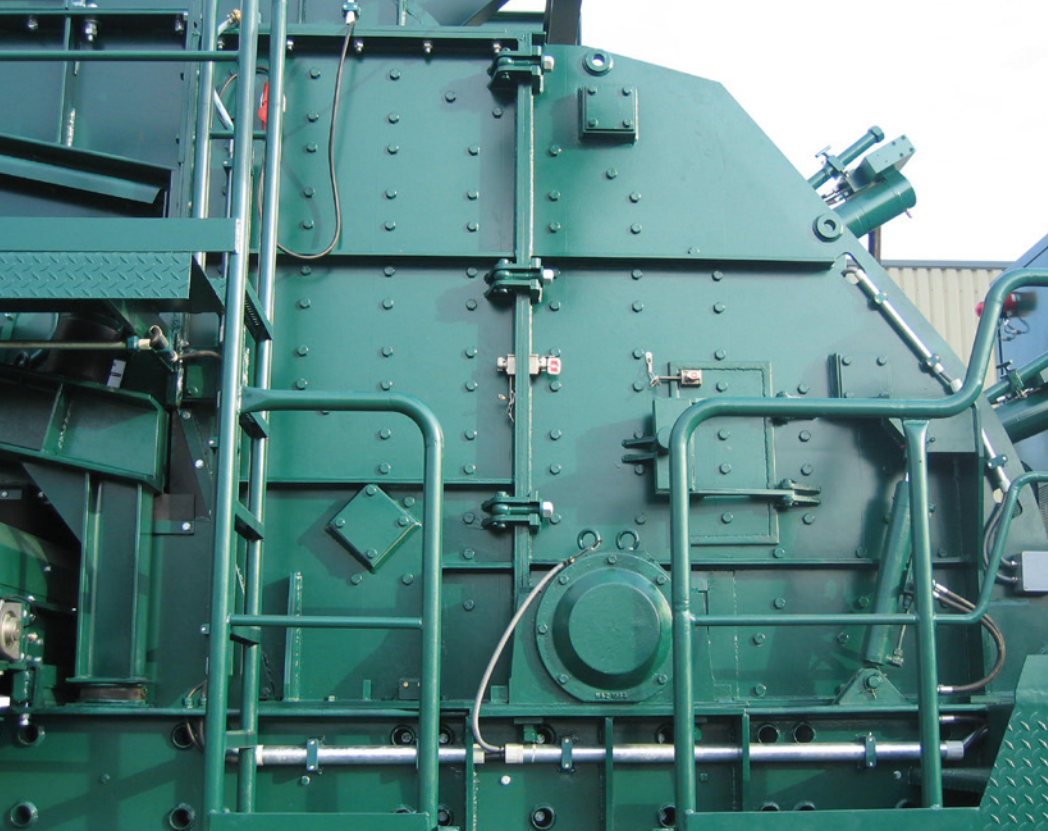

From HAZEMAG's range of products

	<p>Primary Impact Crusher HPI</p>	<p>High crushing degree, large feed size and high throughput rates. Each crusher can be fitted with the optional hydraulic impact apron control system (HAZtronic).</p>
	<p>Impact Roll Crusher HHI</p>	<p>Excellent solution for high flexibility and simplified set-up (no foundations are needed), large feed size, true horizontal crushing with at-grade feed point and delivery of the material to the crushing stage by an integrated chain conveyor.</p>

The hydraulic adjustable impact crusher | HPI

Should overloading, power failure, etc. cause material jamming in the crushing chamber, the impact aprons can be raised hydraulically, allowing the material to pass through the gap thus enlarged. The gap then reverts automatically to its original setting.

The inlet base section is also installed as an impact element; consequently, if jamming does occur in this area despite the generously-sized inlet cross-section, the hydraulics can be utilized to eliminate such problems with minimum effort.

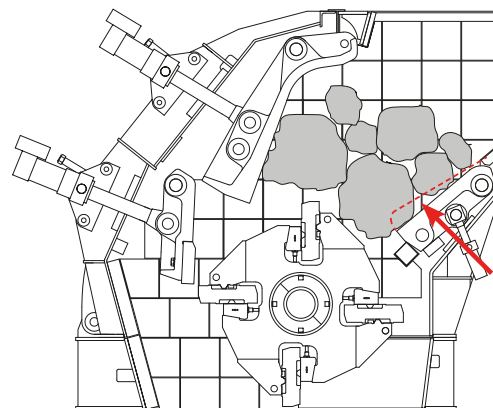
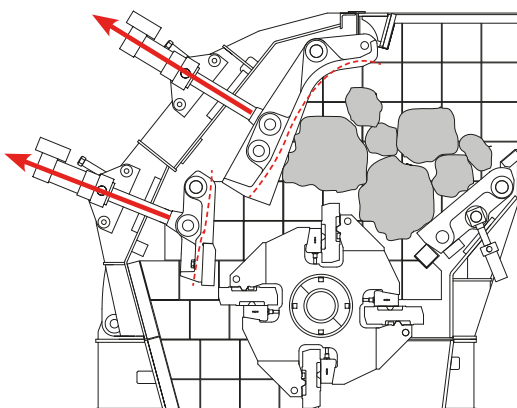

In most cases the impactor does not have to be cleared of material, thus avoiding costly stoppages and safety issues.





Air classifier system

Separation of Light-Weight Materials = Desirable End Product

Beyond the crushing process, the plants technology must also serve the need to process, separate and remove light-weight materials, such as; paper, wood, plastics and other foreign items that are often associated with the processing of demolition debris. Due to its potentially high level of contamination, the consideration for manual sorting and removal is not practical and certainly uneconomical.

For this task, HAZEMAG has developed an air classifier system for the efficient, highly effective removal of light-weight materials to the highest possible degree. The air classifying system utilizes the basic principle of separating materials by the size, density

and weight. This is accomplished by passing the flow of mixed material (stones, wood, paper, etc.) in front of the air classifier where a certain volume of air is being discharged. The air is passed through the stream of material in a transverse direction, permitting its ability to move the lighter particles away from the heavier stones. Once this separation occurs, we now have the ability to direct the light particles in one direction and the heavier stones in another direction. Although this system cannot reach a separation rate of 100 %, it does offer an excellent, proven manner of effectively producing a clean stone product that has been accepted for many uses. The complete system is self-contained, thus reducing concerns that may be associated with dust, noise and the environment.

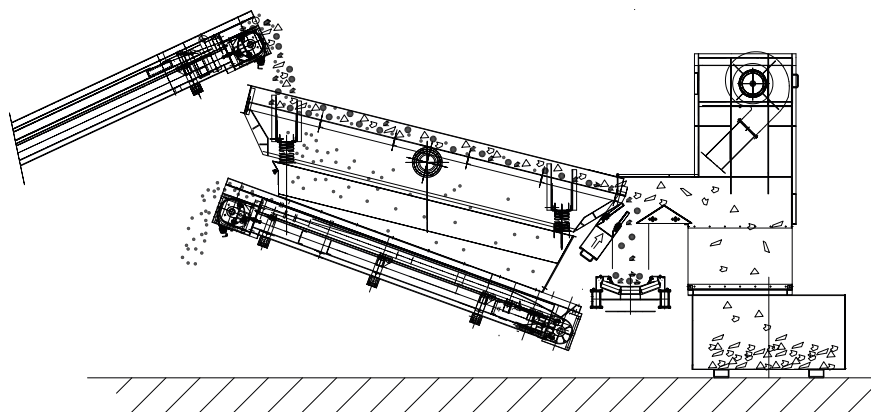
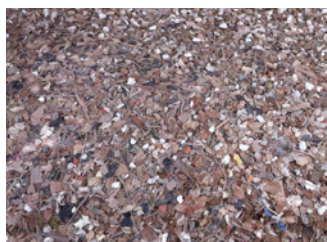

Separated light-weight materials

HAZEMAG air classifier system – prinziple





Service/Parts Support

Spare parts service

The availability of machines and plants has a significant influence on the profitability of a company. Achieving this is the result of knowledge, preventative service programs and the application of high quality, HAZEMAG original spare parts, always in stock and backed by an experience team that is always available to help. In our modern, DP-controlled spare parts inventory in Dülmen, current HAZEMAG machines and customers are supported by an extensive inventory, well over 20,000 different spare and wear parts.

In this regard, HAZEMAG's delivery service guarantees a short-term availability of all spare parts. If a service technician is required for the professional installation of the spare parts or if a qualified consultation is desired, you are at the right place at HAZEMAG.

Inspection Contracts

The continued operation and reliable success of any HAZEMAG component or system is directly related to trained, knowledgeable plant personnel. In this regard HAZEMAG offers customized inspection contracts, ensuring that our customers have the very latest input and assistance from a factory point of view. Depending on the need of the customer, these contracts can vary, but are normally structured to provide a periodic inspection of your HAZEMAG equipment. Preventative and condition based main-tenance inspections are performed by qualified HAZEMAG technicians, contributing to reduced downtime and the avoidance of major repairs.

This partnership ensures that the HAZEMAG machine is providing the maximum yield and that our customers have the advantage over the competition.

Repairs – Modifications – Assemblies

When needed, repairs and machine modifications can be carried out by HAZEMAG professional service technicians, if necessary in shift work around the clock. These highly-trained and motivated service technicians are at your disposal 24 hours every day.

Don't take a risk, always insist on genuine HAZEMAG support: spare parts, service, on-site inspection contracts and around the clock assistance.



HAZEMAG



HAZEMAG – pointing the way.

HAZEMAG & EPR GmbH
Brokweg 75 · 48249 Dülmen, Germany

+49 2594 77-0
+49 2594 77-400

info@hazemag.de
www.hazemag.com