

HAZEMAG



HAZEMAG Drying technology





Partnership

Drying technology

The processing of minerals entails a number of procedural steps; such as crushing, sizing, classifying, and at times the need for drying. In itself, removing moisture from a given material is relatively basic; just introduce hot air. Although this can be calculated with a high level of accuracy, the drying step presents its own unique and sometimes difficult challenges; high diversity in the raw materials, changing material characteristics during the drying process and the true amount of time that is needed in order to achieve our desired goal. Achieving the optimum solution takes know-how, years of proven experience and the correct equipment technology. With that in mind; HAZEMAG delivers solutions!

Partnership

Behind the operation of every HAZEMAG product is found a wealth of experience, backed by a level of partnership and product support that remains second to none. Our application knowledge, equipment flexibility and market competitiveness puts us in a unique position to react to your precise project needs. We call it "Partnership Unlimited – the HAZEMAG Way".

Since 1946: Our journey started in 1946 with our introduction of the impact crusher. Today, our customers benefit from an extensive range of HAZEMAG services; realized in our industry knowledge, qualified experts, proven products, financial resources and innovative technologies and solutions. Now, some 70 years later, we have not forgotten our strongest growth asset; our customers that have looked to us as a proven, reliable partner. Your project starts with planning. As your partner we will introduce the

correct equipment and systems. Our services continue with state of the art manufacturing facilities, equipment supply and delivery, on-site installation, commissioning, training and future spare parts support. Simply put, our partnership will be there, supporting your needs through-out the life cycle of your HAZEMAG equipment; be it a single crusher or a complete system.

Going Forward: The continued operation and reliable success of any HAZEMAG component or system is directly related to trained, knowledgeable plant personnel. HAZEMAG's training concept and support services offer a common sense approach to meeting your needs. Our team of experienced, knowledgeable service technicians are there for you, ensuring that you know and understand your HAZEMAG equipment from every aspect; operation, service needs, safety and optimization.

Material analyses and tests

HAZEMAG offers a range of application support services found in our material testing facility. We have the ability to offer our customers a full scale testing program for the analysis and further understanding of their raw material. For example, we can conduct crushing tests for both fine and coarse grinding. Drying as well as a combination of drying and pulverizing tests can also be carried out with the latest technology and measurements systems. The complete program offers our customers important information and data in regard to through-put rates, wear costs, energy consumption and behavior characteristics for their raw material. These practical and comprehensive results are often looked upon as the basis for the investment decision.





Drying/Drying and Grinding Combination

The decision to dry material or alternatively dry and grind material is driven by the final product goal; what is truly needed? Each industry presents a potential need and opportunity for drying technology. For example;

- **Cement:** clay, trass, chalk, pozzolana, opoka, blast-furnace slag, marl
- **Gypsum:** FGD gypsum, chemical gypsum, anhydrite
- **Ceramic:** clay, kaolin, bentonite
- **Building/Construction:** flue ash, sand
- **Chemical:** aluminium hydroxide, fluorite, tricalcium phosphate filter cake, dicalcium phosphate filter cake, chrome hydroxide filter cake, nickel carbonate filter cake, chrome ore
- **Steel:** cinc mud, blast-furnace slag, iron ore concentrate
- **Lime:** limestone, dolomite, gypsum

In this case, the drying process should be understood as the thermal removal of water from the wet material; achieved by convection. In this case, water is evaporated when the hot gas/hot air comes into contact with the wet material. The hot air is normally produced by the flue gases coming from a hot gas generator; however in many cases this can be facilitated by the use of available, on site exhaust gases. The fuel source for the gas generator is normally supplied by natural gas, heating oil or coal fines (dust).

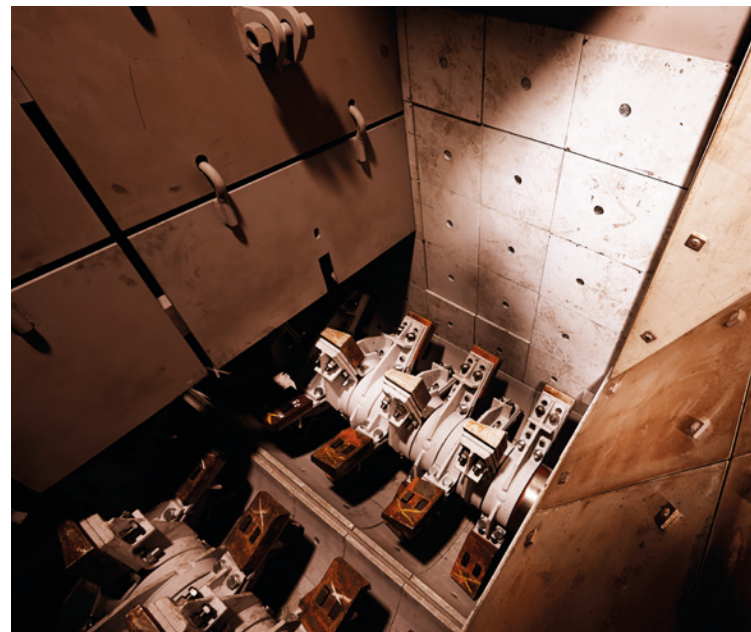



The Drying System

The Drying System: What should be considered?

In order to determine the optimum drying solution, the following important points, among others, should be considered and evaluated.

■ **The characteristics of the material; before and after drying**

It is important to know and to understand the condition of the material in its "wet state"; thus providing the needed knowledge for the design and selection of the feed equipment. Further, it is also important to know and to understand the condition of the material in its "dry state", thus providing the needed knowledge for the design and selection of the product discharge equipment.

■ **The integration of the drying process**

The drying process requires careful planning; taking into consideration the material handling steps that precede drying and the subsequent steps that will follow drying. The complete process must be synchronized; ensuring a smooth, efficient and uninterrupted flow of material throughout the plant.

■ **The properties of the material to be dried**

The selection of the drying system is not possible without a full understanding in regard to the material that must be dried. For example;

- Its ability to absorb water
- Its consistencies
- Its size
- Its abrasiveness
- Its stickiness
- Its thixotropy

Knowing these properties is essential in determining and selecting the optimum drying solution.

■ **The required / available space**

In many cases, the need for the drying process is hindered by the available amount space within the processing plant. Overcoming this is achieved by experience, a range of processing solutions and an industry proven partner.

■ **Mode of operation; constant or interrupted**

Knowing the desired or needed mode of operation also plays an important role in determining the selection and design of the drying system, thus ensuring that the drying plant models the function and material flow as needed.

■ **Installation height of the plant**

This aspect is especially to be considered at the determination of the hot gas and exhaust gas flow rate.

The Drying Plant: Key Component Breakdown

- Feed / handling equipment for the wet material
- Hot gas generator
- Dryer
- Dryer air flow locks; feed and discharge points
- Filter house for de-dusting
- Conveying equipment
- Tubing / Duct Work
- Electrical Instrumentation & Controls (EI&C)

Knowledge of the process parameters in respect of the drying process is also a basic requirement. But also any physical and/or chemical changes in the material to be dried have to be taken into account.





Dried clay



Wet clay



Hammer mill

From HAZEMAG's range of products

	<p>Rapid dryer HRD</p>	<p>Convection dryer with hot gas as drying medium in direct current method with a short dwell time and a high heat economy.</p>
	<p>Hammer mills HUM or HNM</p>	<p>Fine crushing of soft to medium-hard raw materials; an additional option is combined drying and grinding. Besides the pure fine crushing the material is also dried simultaneously in one work step.</p>
	<p>Rotary gate valve HGV</p>	<p>Continuously conveying feed and discharge unit for processes which are carried out under a "slight" low pressure, such as dryers, filters, classifiers, hammer mills etc.</p>
	<p>Pendulum flap gate HPV</p>	<p>Feed and discharge unit for processes which are carried out under a "slight" low pressure, such as dryers, filters, classifiers, hammer mills etc.</p>

Commonalities of HAZEMAG dryer and grinding dryer

- Convection dryer
- Continuous operation mode
- Low pressure operation

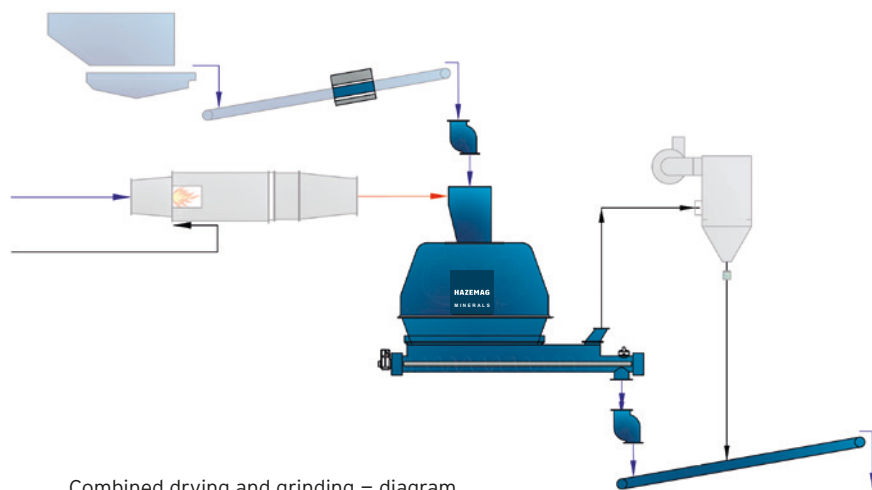

Combined drying and grinding – diagram





Rapid dryer and grinding dryer

Rapid Dryer

The rapid dryer HRD is a field-proven type of dryer and combines the advantages of short-time drying and uniflow drying, as a result of which high efficiency is achieved. With the mechanical whirling of the material to be dried with agitator paddles and simultaneous flow of hot gas through the material, gentle thermal drying is possible in a short time.

With the principle of uniflow drying, the material to be dried and the drying gas pass through the dryer in the same direction. This offers the advantage that high hot gas temperatures can be used for drying in the entry zone without the material being damaged. When the hot gases meet the wet material, intensive water evaporation results with simultaneous decrease of temperature of the drying gas.

This operating principle of the rapid dryer is especially advantageous for the drying of moist, plastic clay and difficult-to-dry filter cake that has been previously mechanically dewatered on belt filters, filter presses, drum filters or centrifuges, e.g. FGD gypsum, chemical gypsum, chromium hydroxide, etc. The material to be dried is de-agglomerated. This results in a very large surface area and a whirling of the material particles, which enables intensive material and heat exchange. Thanks to its compact design, only a relatively small space is required.

Combined grinding and drying

For the simultaneous grinding and drying of materials, HAZEMAG Hammermills type HUM and HNM are used. In this combined process, grinding and drying complement each other very well and mutually support each other. The thermal stresses promote the comminution process. The larger product surface area produced by grinding is very conducive to the drying process.

Combined grinding and drying units are also short resistance time dryers and are used when fine grinding and drying are required at the same time. Typical applications are limestone, clays, chalk, dolomite, gypsum and anhydrite. Drying is performed according to the uniflow principle, the material being heated to a limited extent

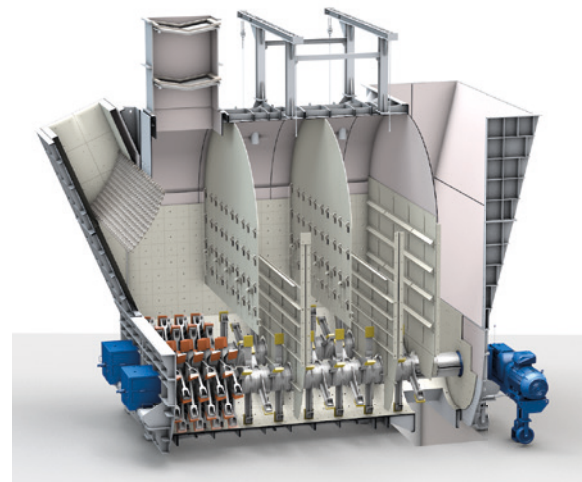

Rapid dryer HRD – diagram





Service/Parts Support

Spare parts service

The availability of machines and plants has a significant influence on the profitability of a company. Achieving this is the result of knowledge, preventative service programs and the application of high quality, HAZEMAG original spare parts, always in stock and backed by an experience team that is always available to help. In our modern, DP-controlled spare parts inventory in Dülmen, current HAZEMAG machines and customers are supported by an extensive inventory, well over 20,000 different spare and wear parts.

In this regard, HAZEMAG's delivery service guarantees a short-term availability of all spare parts. If a service technician is required for the professional installation of the spare parts or if a qualified consultation is desired, you are at the right place at HAZEMAG.

Inspection Contracts

The continued operation and reliable success of any HAZEMAG component or system is directly related to trained, knowledgeable plant personnel. In this regard HAZEMAG offers customized inspection contracts, ensuring that our customers have the very latest input and assistance from a factory point of view. Depending on the need of the customer, these contracts can vary, but are normally structured to provide a periodic inspection of your HAZEMAG equipment. Preventative and condition based maintenance inspections are performed by qualified HAZEMAG technicians, contributing to reduced downtime and the avoidance of major repairs.

This partnership ensures that the HAZEMAG machine is providing the maximum yield and that our customers have the advantage over the competition.

Repairs – Modifications – Assemblies

When needed, repairs and machine modifications can be carried out by HAZEMAG professional service technicians, if necessary in shift work around the clock. These highly-trained and motivated service technicians are at your disposal 24 hours every day.

Don't take a risk, always insist on genuine HAZEMAG support: spare parts, service, on-site inspection contracts and around the clock assistance.



HAZEMAG



HAZEMAG – success through efficiency.

HAZEMAG & EPR GmbH
Brokweg 75 · 48249 Dülmen, Germany

+49 2594 77-0
+49 2594 77-400

info@hazemag.de
www.hazemag.com